



SITE TESTING STANDARDS FOR METHANE

This Information Bulletin establishes the standard protocol for Site Testing that provides design input data for methane mitigation systems required by Division 71 of the Los Angeles Building Code.

The work plan for site testing is summarized in three primary steps:

- Step 1 - Schedule Site Testing
- Step 2 - Conduct Shallow Soil Gas Test
- Step 3 - Conduct Gas Probe Test

The site testing results from these steps are to be organized in a report and included with the building permit application.

I. SITE TESTING FOR METHANE

Site testing shall be conducted using the following three-step testing protocol described in this Bulletin to determine the concentration and pressure of the subsurface methane gas for the design of methane hazard mitigation systems.

STEP 1 - SCHEDULE SITE TESTING

Site Testing should be scheduled before any site grading. If Site Testing after site grading is unavoidable, then Site Testing shall be conducted at least 30 days after any site grading.

STEP 2 - CONDUCT SHALLOW SOIL GAS TEST

1. Methane gas concentration measurements for the Shallow Soil Gas Test (See page 8 for the Shallow Soil Gas Test Equipment Set-Up) shall be taken as follows:
 - a. A minimum of two per project site, and at a rate of one sample per 10,000 square feet of site area, or portion thereof, and
 - b. At a depth of not less than 4 feet below ground surface, or
 - c. If ground water is found less than 4 feet below ground surface, then the depth of the

Shallow Soil Gas Sample shall be taken above the ground water level.

2. Review the methane gas concentration data from the Shallow Soil Gas Test and site observations to identify locations where high gas concentrations of methane gas may be found.
3. Shallow Soil Gas measurements shall be made at least once and may be taken at anytime before the installation of Gas Probe Sets.

STEP 3 - CONDUCT GAS PROBE TEST

1. The location of Gas Probe Sets shall be based on the information from the Shallow Soil Gas Test where the highest concentration of soil gas may be found.
2. Methane gas concentration and pressure measurements for the Gas Probe Tests (See page 9 for the Gas Probe Set Equipment Set-Up) shall be taken as follows:
 - a. There shall be at least one gas probe set for every 20,000 square feet or portion thereof of site area. Regardless of area, all sites shall install a minimum of two gas probe sets.
 - b. Each Gas Probe Set shall consist of three probes, installed at approximate sampling depths of 5 feet, 10 feet and 20 feet below the elevation of the lowest building slab or footing.
 - c. Gas Probe Sets shall be installed a minimum of 12 inches above ground water table.
 - d. Gas Probe Sets are not required to be installed below the ground water level.
 - e. Shallow Soil Gas data, collected as described in Step 2, may be used in lieu of Gas Probe Set data when ground water is found less than 5 feet below the ground surface.
3. Record data from the Gas Probe Sets as follows:
 - a. Two sequential measurements shall be taken, with a minimum 24-hour interval following placement of the Gas Probe Sets. Samples shall not be collected during increasing barometric pressure from a pre-frontal weather condition.
 - b. Site testing data shall be recorded on Form 1 – Certificate of Compliance for Methane Test Data and certified by the engineer (see pages 4 and 5).

II. REPORTING SITE TESTING RESULTS

The methane site testing data shall be organized as described below:

1. The Certificate of Compliance for Methane Test Data, Form 1, shall be completed, stamped and signed by an engineer, geologist or architect. This form shall be attached to the methane mitigation construction plans.
2. Site Testing Plan showing:

- a. Locations of Shallow Soil Gas Samples and Gas Probe Sets.
- b. Locations and dimensions of the proposed and existing building footprints.

III. CERTIFICATE OF COMPLIANCE AND GAS COLLECTION EQUIPMENT

Form 1- Certificate of Compliance for Methane Test Data

Table I - Gas Collection Equipment

Shallow Sample Equipment Set-Up

Gas Probe Set Equipment Set-Up

FORM 1 - CERTIFICATE OF COMPLIANCE FOR METHANE TEST DATA

Part 1: Certification Sheet

Site Address: _____

Legal Description: Tract: _____ Lot: _____ Block: _____

Building Use: _____

Architect's, Engineer's or Geologist's Stamp:

Name of Architect, Engineer, or Geologist: _____

Mailing Address: _____

Telephone: _____

Name of Testing Laboratory: _____

City Test Lab License #: _____

Telephone: _____

I hereby certify that I have tested the above site for the purpose of methane mitigation and that all procedures were conducted by a City of Los Angeles licensed testing agency in conformity with the requirements of the LADBS Information Bulletin P/BC 2002-101. Where the inspection and testing of all or part of the work above is delegated, full responsibility shall be assumed by the architect, engineer or geologist whose signature is affixed thereon.

Signed: _____ date _____

Required Data:

- Project is in the (Methane Zone) or (Methane Buffer Zone).
- Depth of ground water observed during testing: _____ feet below the Impervious Membrane.
- Depth of Historical High Ground Water Table Elevation*: _____ feet below the Impervious Membrane.
- Design Methane Concentration**: _____ parts per million in volume (ppmv).
- Design Methane Pressure***: _____ inches of water column.
- Site Design Level: (Level I, Level II, Level III, Level IV, Level V) with _____ inches of water column.

De-watering:

- De-watering (is) (is not) required per Section 91.7104.3.7.
- Pump discharge rate _____ cubic feet per minute per reference geology or soil report: _____ dated _____.

Additional Investigation:

- Additional investigation (was) (was not) conducted.

Latest Grading on Site:

- Date of last grading on site (was) (was not) more than 30 days before Site Testing.
- See Attached explanation of the effect on soil gas survey results by grading operations.

Notes:

* Historical High Ground Water Table Elevation shall mean the highest recorded elevation of ground water table based on historical records and field investigations as determined by the engineer for the methane mitigation system.

** Design Methane Concentration shall mean the highest recorded measured methane concentration from either Shallow Soil Gas Test or any Gas Probe Set on the site.

*** Design Methane Pressure shall mean the highest total pressure measured from any Gas Probe Set on the site.

TABLE 1 - DATA COLLECTION EQUIPMENT

| Parameter | Equipment or Procedure | Detection Limit |
|-------------------------------|---|--------------------------|
| Barometric Pressure | Barometer or GA-90 | 0.1" of Hg |
| Gas Probe Pressure | Pressure Gauge | 0.1" of H ₂ O |
| Methane Concentration | Landtec GA-90 (Field) or EPA 8015 (Lab) | 0.1% or 1,000 ppm |
| Combustible Gas Concentration | LTX-310 (Field) or EPA 8015 (Lab) | 0.1% or 1,000 ppm |

Notes for Table 1:

1. Gas Probe Sets shall be capable of collecting data for both soil gas pressure and methane concentration.
2. Instruments and test procedures used to determine gas pressure and concentrations shall be in accordance with the test equipment manufacturer's instructions and the listed Detection Limits.
3. Portable Gas Sampling Instruments shall consist of infrared gas analyzer or other combustible gas analyzers. Photo Ionization Detectors (PIDs) shall not be used to measure methane concentrations. Flame Ionization Detectors (FID's) may be used as the primary detector for gas probe monitoring. All portable gas sampling instruments shall be calibrated daily using a laboratory certified methane calibration gas.

SHALLOW SOIL GAS TEST EQUIPMENT SET-UP

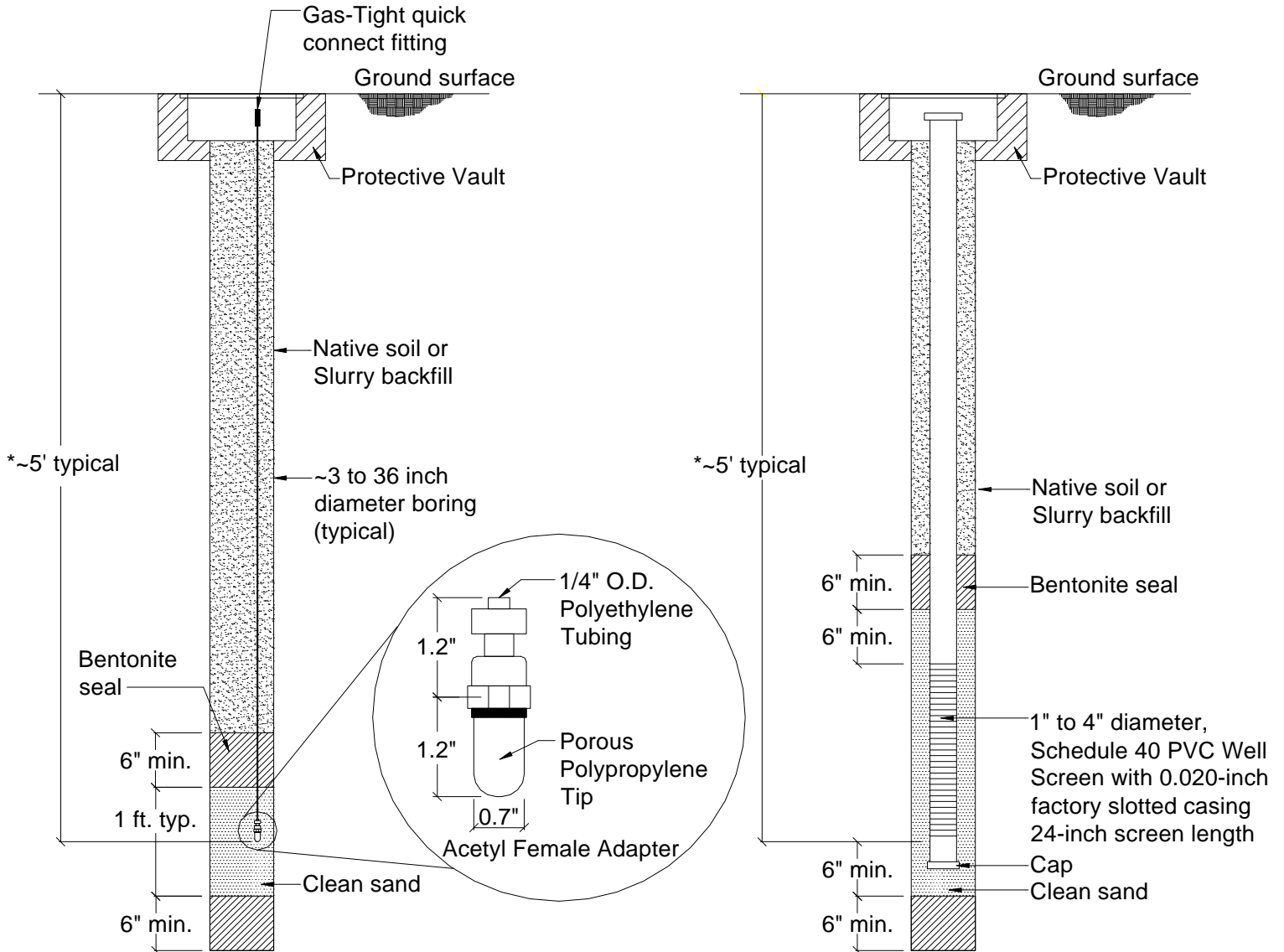

*Note: Measurement from Shallow Soil Gas Test shall be taken above ground water level.

GAS PROBE TEST EQUIPMENT SET-UP

Option A - Polypropylene Tip

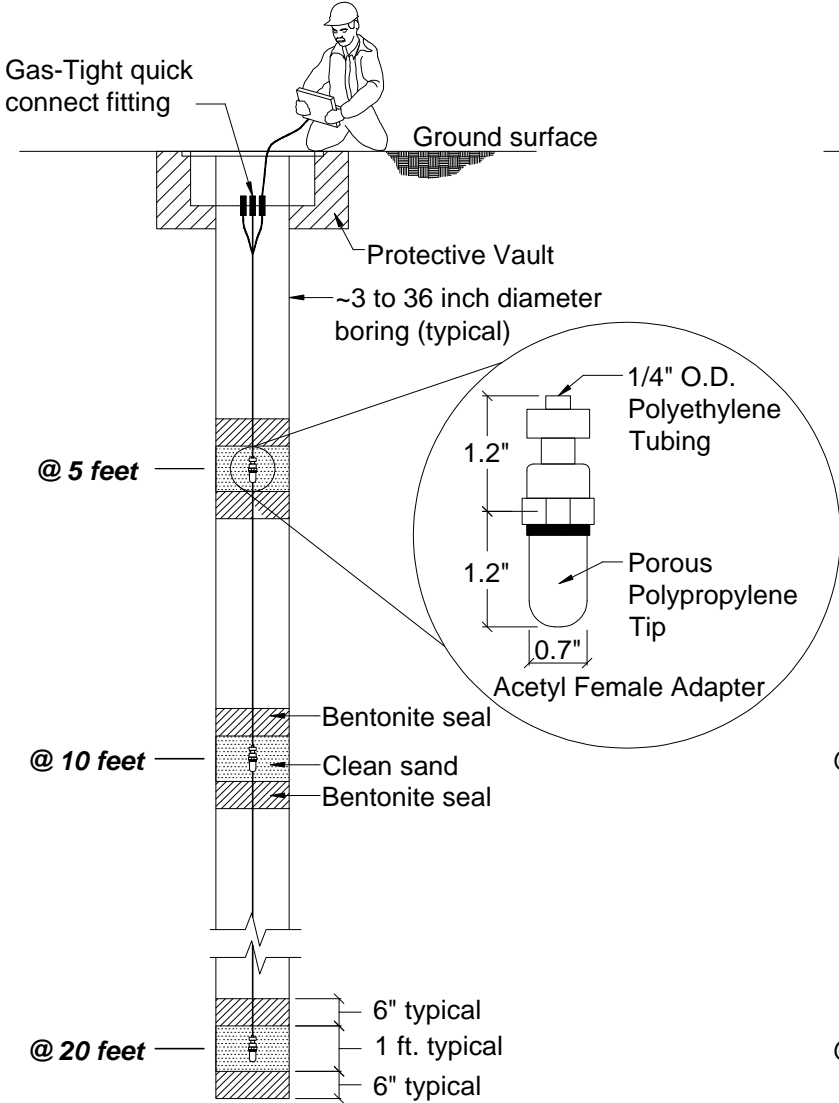

Option B - Slotted PVC Casing

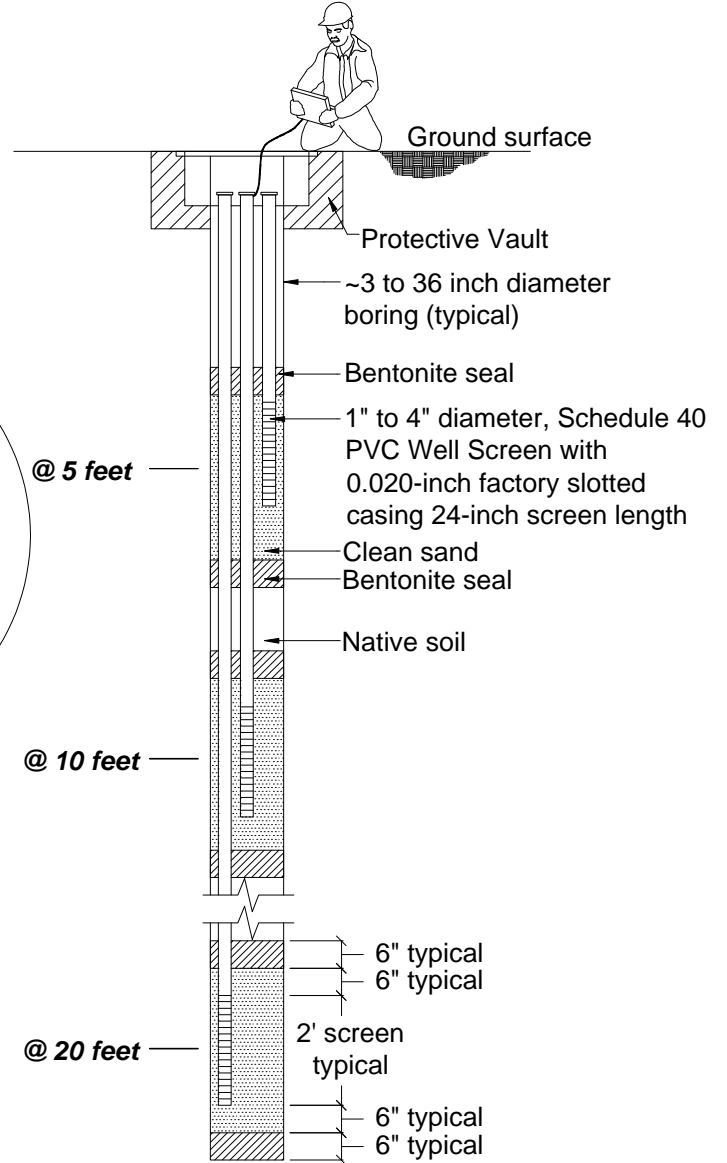

*Note: Gas Probe Test shall not be install below ground water level.